

EXHIBIT CATEGORY

equal protection and due process.

"If the right to marry is a fundamental right, then it must be conceded that an infringement of that right by means of a racial restriction is an unlawful infringement of one's liberty."
-The Lovings' lawyer, Paul V. Shapiro, a 1967 Supreme Court case

"The Lovings have the right to go to sleep at night, knowing that should they not awake in the morning their children would have the right to inherit from them, under intestacy they have the right to be secure in knowing that if they go to sleep and do not wake in the morning, that one of them, a survivor of them, has the right to social security benefits."
-Bernard S. Cohen

"All persons born or naturalized in the United States and subject to the jurisdiction thereof, are citizens of the United States and of the State wherein they reside. No State shall make or enforce any law which shall abridge the privileges or immunities of citizens of the United States; nor shall any State deprive any person of life, liberty, or property, without due process of law; nor deny to any person within its jurisdiction the equal protection of the laws."
-The Fourteenth Amendment of the United States Constitution

"Marriage, as creating the moral relation in life, as having moral and civil status, has also subject to the control of the Legislature."
-D. McManis Governor of Va.

"If the State feels like the life better protected by a policy of integrity... then it has the right such a field. The fact that the conclusions may differ from of other groups should not unless minority groups are to... privileges that are again of the majority."
-T.W. Brown Attorney General

Deciding On Love

"We hope we have put to rest the last vestiges of racial discrimination that were supported by the laws in Virginia and all over the country."
-Bernard S. Cohen (his winning the case)

After nine long years of fighting for their right to marry, the Lovings had their verdict. On June 12th, 1967, the Supreme Court ruled it was not the responsibility of the right of government to maintain white supremacy. The Lovings finally won their right to marry.

"We have consistently demonstrated the constitutionality of measures of rights of citizens on account."
-Chief Justice Earl Warren

Miscegenation Laws Are Struck Down



Paul and Mildred Loving

"There can be no doubt that restricting the freedom to marry solely because of racial classification, violates the central meaning of the equal protection clause of the Fourteenth Amendment... To deny this fundamental freedom on so invidious a basis as the race of the citizens of the state is surely to deprive all of the state's citizens of liberty without due process of law."
-Chief Justice Earl Warren

"It's a burden... It's hard to... I can't put my arm around my..."
-Paul Loving (about winning the case)

"The fact that Virginia's marriage laws demonstrate that must stand on the measures designed to..."
-Chief Justice Earl Warren

STATES WITH MISCEGENATION LAWS



1948



1958



1968

B. EXHIBIT

An exhibit is a visual representation of your research and interpretation of your topic's significance in history, much like a small museum exhibit. The analysis and interpretation of your topic must be clear and evident to the viewer. Labels and captions should be used creatively with visual images and objects to enhance the message of your exhibit.

Part II, Rules for all Categories, applies to exhibits.

Rule 1: Size Requirements

The overall size of your exhibit when displayed for judging must be no larger than 40 inches wide, 30 inches deep, and 6 feet high. Measurement of the exhibit does not include the table on which it rests; however, it would include any stand that you create and any table drapes. Circular or rotating exhibits or those meant to be viewed from all sides must be no more than 30 inches in diameter. (See diagram below.)

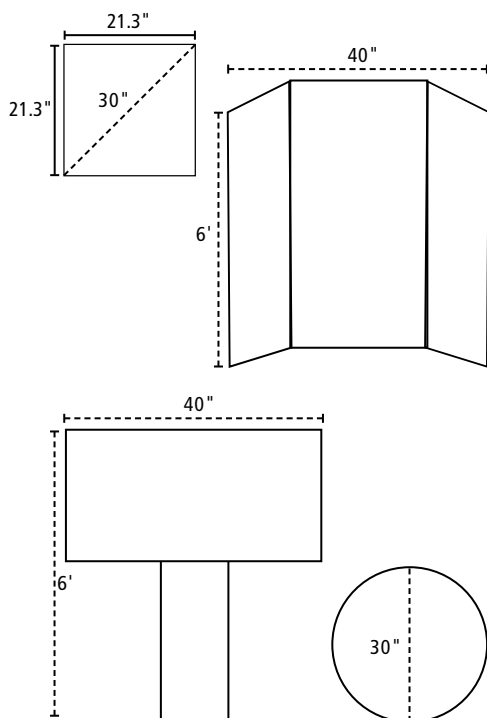

Rule 2: Media Devices

Media devices (e.g., tape recorders, projectors, video monitors, computers) used in an exhibit must not run for more than a total of 3 minutes and are subject to the 500-word limit (Rule 3). Viewers and judges must be able to control media devices. Any media devices used must fit within the size limits of the exhibit. Any media devices used should be integral to the exhibit—not just a device to bypass the prohibition against live student involvement.

NOTE: For example, a brief excerpt from a taped student-conducted oral interview or a dramatic reading might be appropriate, but taped commentary or analysis is inappropriate.

Rule 3: Word Limit

There is a 500-word limit that applies to all text created by the student that appears on or as part of an exhibit entry. This includes the text you write for titles, subtitles, captions, graphs, timelines, media devices (e.g., video, slides, computer files) or supplemental materials (e.g., photo albums, scrapbooks, etc.) where you use your own words.

NOTE: A date counts as one word, while each word in a name is individually counted. For example, January 1, 2006 counts as one word, but John Quincy Adams counts as three.

Words such as "a," "the" and "of" are counted as one word each.

Brief citations crediting the sources of illustrations or quotations included on the exhibit do not count toward the 500-word limit.

NOTE: Be careful that your message is clear and contained on the exhibit itself; judges have little time to review supplemental material. Extensive supplemental material is inappropriate. For example, oral history transcripts, correspondence between you and experts, questionnaires, and other primary or secondary materials used as sources for your exhibit should be cited in your bibliography but not included as attachments to your bibliography or exhibit.